



34 SCHOOL STREET • LITTLETON, NH 03561 • PHONE 603-444-4111 • FAX 603-444-1343 • www.horizonsengineering.com

March 20, 2017

Mr. Don Vaughan
President
New England Service Company
37 Northwest Drive
Plainville, CT 06062

Subject: Rosebrook Water Company Bretton Woods NH Hydraulic Modeling

Dear Mr. Vaughan,

At the request of New England Service Company, Horizons Engineering Inc. has collected data on the Bretton Woods water distribution infrastructure, performed a field visit, and completed hydraulic modeling of existing and proposed future conditions. The overall goal of these efforts was to finalize the proposed approach for implementing a system-wide reduction in operating pressures. This letter report summarizes the project's background, field visit findings, hydraulic modeling results, proposed modifications, anticipated easements, and next steps for implementing the project.

Background and Existing Conditions

The Bretton Woods water distribution infrastructure is managed by the Rosebrook Water Company under PWSIDs 0382010, 0388010, and 0388020. This project expanded on a hydraulic model prepared by Horizons in 2009 as well as a preliminary report by Horizons in 2016 for the System Evaluation for Pressure Reduction. Following completion of this study New England Service Company indicated that the preferred approach was to move forward with a project that allows reduction of operating pressures to less than 120 psi at the main system pump station. Additional pump stations are proposed to serve higher areas of the system that cannot be adequately served once pressures are reduced.

A map of the existing distribution system is provided in **Attachment 1**. System data for 2015 through 2016 indicate average system demand of 111,668 gallons per day (average flow of 77.6 gallons per minute). The existing system has a single pressure zone with a gravity water storage tank at elevation 2010. The current system configuration results in system pressures exceeding 180 psi in the lowest elevations the system. These high pressures are exacerbated by intermittent water-hammer events that occasionally cause instantaneous pressure surges in excess of 200 psi.

17 Sunset Terrace
Newport, VT 05855
Ph.: 802-334-6434
Fax: 802-334-5602

34 School Street
Littleton, NH 03561
Ph: 603-444-4111
Fax: 603-444-1343

176 Newport Rd., PO Box 1825
New London, NH 03257
Ph. 603-877-0116
Fax: 603-526-4285

Rosebrook Water Company staff provided extensive information on the infrastructure and operation of the existing system that substantially improved the accuracy of the effort, for which we are extremely grateful.

Field Visit

On Wednesday, February 15, 2017, Mark Nance of Horizons Engineering met with Ms. Nancy Oleson of Rosebrook Water Company to discuss the water system and to inspect the water pump station. The water system information provided critical operating information for the hydraulic modeling. The water pump station visit provided instantaneous operating data in addition to further detail on the system configuration.

Horizons also met with Omni Resorts Mount Washington staff Mr. John Santaniello, Mr. Kolin Bailey, Mr. Jason Doyle, and a staff plumber to attempt to determine the fire flow design requirements for various large facilities, including the Mount Washington Hotel and Spa/Conference Center. We inspected the Administration Building, Bretton Arms Inn, Bretton Woods Nordic Center, Mount Washington Hotel, and the Spa/Conference Center. We also visited the drawing archives room in the Mount Washington Hotel basement to search for fire flow design requirements on various construction projects' contract drawings. Fire flow requirements were located for the Spa/Conference Center, however none were identified for the hotel or other structures.

Horizons performed preliminary inspections of each potential booster station site to assess technical and aesthetic siting concerns. As a result of the inspections, each booster station location was adjusted from that generally shown in the 2016 report.

Hydraulic Modeling

The modeling effort updated an existing, eight-year-old Water Cad hydraulic model of the distribution system, which was then examined in the context of the 2016 evaluation recommendations for alternative options to reduce operating pressures. After reviewing the existing conditions model, Horizons completed modeling to assess two scenarios that reduce distribution system pressures to below approximately 130 psi. Based on some preliminary calculations and testing, two alternatives were modeled to assess their viability.

ALTERNATIVE 1 – EXISTING TANK, BOOSTER PUMP STATIONS/PRVs: Modify the existing well pumps to serve the lowest pressure zone (Zone 1) and install three booster stations to serve higher elevations (Zones 2CR, 2MWP, and 2RT). The well pump modifications would include a minimum of adding a variable frequency drive (VFD) to Pump 2 and replacing the Pump 2 motor with an inverter-duty motor to be compatible with a VFD. The wells would pump into Zone 1 based on storage tank elevation setpoints, and the water storage tank would be filled by the Rosebrook Townhomes booster station. Based on the modeling results, it might be possible to continue to use the two existing well pumps, however complete replacement might be necessary to adequately reduce their flow and pressure capacity.

ALTERNATIVE 2 – EXISTING TANK, NEW SUPPLY PIPELINE/PRVS: Use the existing well pumps to pump directly to the existing water storage tank via a new dedicated pipeline. The distribution system would then be fed by gravity off the existing storage tank and would require two booster stations to serve higher elevations. The distribution system would have four separate pressure zones: Zone 1 (lowest elevation), Zone 2CR (fed by a new booster station), Zone 2MWP (fed by a new booster station), and Zone 2RT (fed by gravity from the existing storage tank). The dedicated pipeline between the wells and the storage tank would have no supply taps, would generally follow existing water pipeline alignments, and would require high pressure (~190 psi) at the existing well pump house.

The hydraulic modeling was based on the available information. A detailed discussion of the modeling assumptions and results is provided in **Attachment 2**.

Proposed Modifications

After discussion of Horizons' initial findings, New England Service Company selected Alternative 1 as the preferred modification set to reduce operating pressures throughout the system. Alternative 1 consists of the following major improvements, which are shown on **Attachment 1**:

1. Install a variable frequency drive and inverter duty motor on existing well pump 2 as well as control communications with the new Rosebrook Townhomes booster station.
2. Install ~350 feet of 8-inch pipeline from the west end of Dartmouth Road to the north end of Mount Adams Lane.
3. Install ~40 feet of 16-inch pipeline from the 16-inch main in Base Station Road to the 8-inch hotel supply pipeline at a location north of the Stables.
 - a. Based on the model results, an additional ~2,620 feet of 16-inch pipeline is recommended to loop together several buildings near the Mount Washington Hotel as well as to replace the existing 8-inch hotel supply pipeline which will be undersized for future demands.
4. Install one pressure reducing valve in the Rosebrook Townhomes development west of townhome 10.
5. Install one pressure reducing valve at the north corner of the intersection of Mount Adams Lane and Hartford Lane.
6. Install one booster pumping station in the Crawford Ridge development northwest of unit 22.
7. Install one booster pumping station in the Mount Washington Place development on the west side of Hannah Loop east of unit 100.
8. Install one booster pumping station in the Rosebrook Townhomes development on the south side of Rosebrook Lane south of unit 50.

Easements

The following summarize the locations of anticipated easements for each modification component and contact information.

1. ~350 feet of 8-inch pipeline. This pipeline would route along property lines between four parcels at the north end of Mount Adams Lane: 210-016, 210-017, 211-048, and 211-049.
 - a. 210-016: Manning Realty Trust II, 13 Rockyledge Road, Swampscott, MA 01907
 - b. 210-017: Robert and Donna Manning, Trustee Manning Realty Trust III, 15 Rockyledge Road, Swampscott, MA 01907
 - c. 210-048: Robert Manning, Trustee Manning Realty Trust III, 13 Rockyledge Road, Swampscott, MA 01907
 - d. 210-049: Robert and Donna Manning, Trustee Manning Realty Trust III, 13 Rockyledge Road, Swampscott, MA 01907
2. ~50 feet of 16-inch pipeline. This short interconnection would occur mostly in the right of way of Base Station Road with some possibility of incursion into parcel 210-008.
 - a. 210-008: Omni Mount Washington, LLC, 4001 Maple Avenue, Suite 600, Dallas, TX 75219
3. PRV in Rosebrook Townhomes. This valve would be located in a new manhole in the ski area west of the Learning Center Quad unloading zone.
 - a. 211-014: Omni Mount Washington, LLC, 4001 Maple Avenue, Suite 600, Dallas, TX 75219
4. PRV in Mount Adams Lane. This valve would be located in a new manhole in the Mount Adams Lane right of way.
5. Booster station in Crawford Ridge. This booster station would be located west of Crawford Ridge Road in parcel 211-015.
 - a. 211-015: Crawford Ridge Homeowners Association, Route 302, Bretton Woods, NH 03575
6. Booster station in Mount Washington Place. This booster station would be located west of Hannah Loop in parcel 211-025.
 - a. 211-025: Mount Washington Place Condo Association, Route 302, Bretton Woods, NH 03575
7. Booster station in Rosebrook Townhomes. This booster station would be located south of Rosebrook Lane either in the Rosebrook Lane right of way or in parcel 211-004.
 - a. 211-004: Jack Sylvester 2012 Family Trust, P.O. Box 48, Orrs Island, ME 04066

Next Steps

Following are the next major steps to the pressure reduction project:

- Rosebrook Water Company to confirm the proposed Alternative 1 approach is acceptable.
- Confirm easements are available from the property owners.
- Perform a topographic and utility survey of each proposed improvement location.
- Perform final design and prepare construction documents, including determining final selection of booster station and pressure reducing valve criteria.

Thank you for the opportunity to be of service. We look forward to continuing to work with you toward the implementation of the desired improvements. If you have any questions, please contact me at my office phone number of 603-444-4111 extension 18.

Very truly yours,
Horizons Engineering, Inc.



Jon L. Warzocha, P.G.
CEO

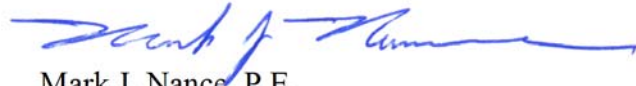

Mark J. Nance, P.E.
Senior Project Manager

Attachments: Attachment 1 Overall Plan
Attachment 2 Hydraulic Model Evaluation

HEI Project 17002

<THE ENTIRETY OF THIS PAGE HAS BEEN MARKED AS CONFIDENTIAL>

There were two primary purposes for the modeling. The first was to determine the water supply capacity of the existing system to establish the baseline performance, including identifying its high pressure areas and any hydraulic restrictions. The second was to evaluate the optimal configuration and settings for planned system modifications that would reduce pressure in the lowest system areas.

Water distribution system modeling uses a computer program to simulate the flow of water through the distribution network under various conditions. The modeling was performed using the Bentley stand-alone WaterCAD version V8i computer program for both steady-state and extended period simulations.

EXISTING SYSTEM

The existing system has a single pressure zone with service connections at elevations from approximately 1560 to 1845 feet. Pump performance curves for the two supply wells were input into the model using curves provided by the Rosebrook Water Company (RWC) as summarized in the following table.

Table 1 Existing Well Pump Performance Characteristics at Full Speed

Pump	Shutoff Head, ft	Design Flow, gpm	Head, ft	Max Flow, gpm	Head, ft
Well Pump 1 (50 hp)	550	300	475	475	335
Well Pump 2 (60 hp)	693	350	495	500	290

Notes: 1. Well Pump 1 = Sulzer JTS-10AC, 10-stage, 1780 rpm, 7.36-inch impellers
 2. Well Pump 2 = Xylem 7CLC, 6-stage, 3450 rpm, 5-inch impellers

Pump controls were based on water storage tank elevations reported by operations staff as follows. While the tank diameter was measured as part of a recent project, the tank depth and invert elevation are not available. The tank volume is reported by different documentation as 600,000 and 650,000 gallons. Operations staff reports the two well pumps are programmed with the same controls and an automatic alternator switches the active pump. Since Pump 1 has a lower pumping capability than Pump 2, Pump 2 was turned off in the model for a conservative assessment of pump supply.

Existing water storage tank: Base elevation = 1991 feet ASSUMED
 Diameter = 90 feet → 47,586 gallons stored per foot of depth
 Maximum water surface elevation = 2004.66 feet ASSUMED

Pump 1 controls: Turns on if tank water depth is less than 8.9 feet = elevation 1999.9
 Turns off if tank water depth is equal to 9.3 feet = elevation 2000.3

Pump 2 controls: Turns on if tank water depth is less than 8.9 feet = elevation 1999.9
 Turns off if tank water depth is equal to 9.3 feet = elevation 2000.3

Water production data from 2015 and 2016 is shown in the following figure.

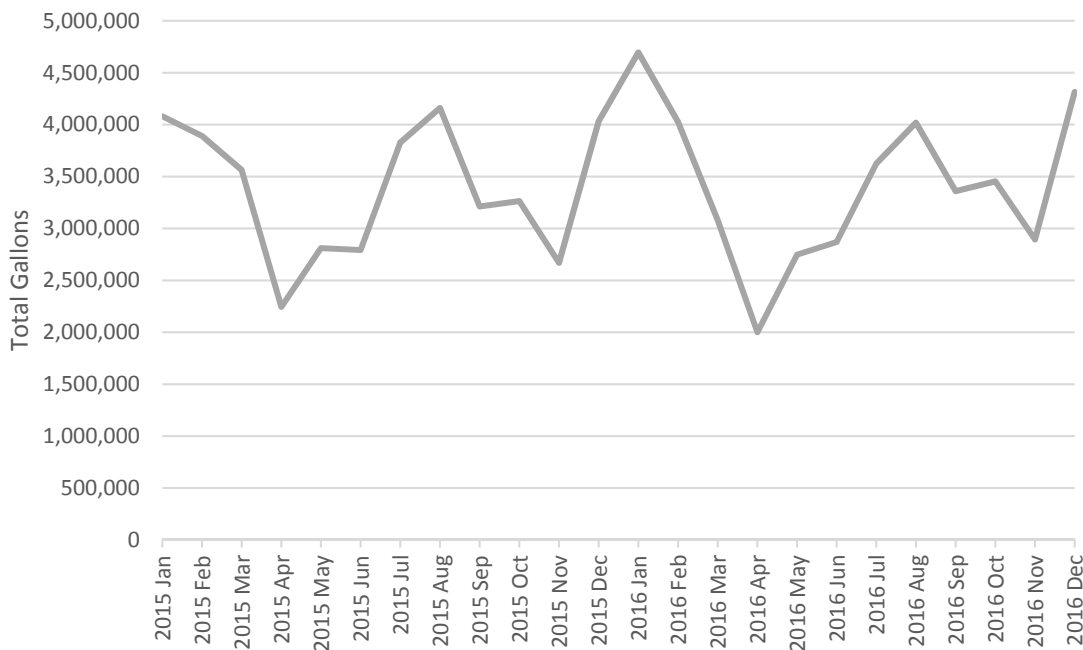

Figure 1 Rosebrook Water System Monthly Water Production

The average total gallons per day (gpd) were 111,086 in 2015 and 112,248 in 2016, which shows consistent water demands between the years. **Figure 1** shows peak demands occur in the winter and the late summer, which reflects the seasonal nature of the community. The peak months were December through March and July through October. During the peak months, the average total gallons per day were 123,070 in 2015 and 124,779 in 2016.

Based on this data, the following water demands were used for modeling the existing system:

- Average daily demand (ADD) (from 2016) = 112,248 gpd = 77.9 gpm
- Maximum day demand (MDD) (from June 26, 2015) = 414,000 gpd = 287.5 gpm = 3.69 x ADD
 - Used 4.0 x Average daily demand = 311.6 gpm
- Peak hour demand (PHD): no data, used 8.0 x Average daily demand = 623.2 gpm

Although the ratios used for MDD and PHD are higher than typical industry values and the New Hampshire Department of Environmental Services (NHDES) value in Eng-Wq 405.19, this seasonal community's peaking characteristics are expected to be higher due to vacation users compared to a full-time resident community. Due to the seasonal water demands, actual water distribution is expected to vary throughout the year as well as day to day. This is due to varying occupancy: some homes might have large taps but be unoccupied most of the year.

The distribution system has 393 residential taps and 19 commercial taps for a total of 412 service connections. The demands were distributed through the system by calculating the percentage of

flow for each tap or residential area based on the 2016 total meter readings as summarized in the following table.

Table 2 Existing Taps and Water Distribution

Area	Taps					Demand Distribution
	5/8"	1"	2"	3"	6"	
Residential						
Crawford Ridge	22					1.05%
Dartmouth Ridge	13	2				1.13%
Fairway Village	50					2.25%
Forest Cottages	54					2.30%
Mount Madison		10				0.45%
Mount Washington Homes	5	4				0.74%
Mount Washington Place	105					5.96%
Mountain View	15					0.81%
Presidential View		15				0.63%
River Front	9					0.50%
Rosebrook Townhomes	28					1.67%
Stickney Circle	51					2.13%
Stone Hill		10				0.48%
Commercial						
Administration Building		1				0.29%
Alpine Club Bathroom Trailer and Kitchen	1	1				0.22%
Arms Inn		1				2.93%
Caretakers Home	1					0.03%
Drummonds Ski Shop	1					0.08%
Fabyans	1					1.07%
First Aid Building	1					0.04%
Golf/Nordic Building		1				1.00%
Irving Store	1					0.27%
Mount Washington Hotel					1	67.23%
Outdoor Pool & Cabana			1			1.54%
Real Estate Office/Peabody & Smith	1					0.02%
Ski Area and Maintenance Building	1		1			3.58%
Spa Building				1		1.34%
Sports Club/Rosebrook Recreation Center						0.00%
Stables	1					0.28%

Notes: 1. The Sports Club/Rosebrook Recreation Center is currently not in use. Its meter was removed in February 2016.

2. Two portable meters are used for filling the ice rink, snowmaking for the tubing hill only, and testing the ski run snowmaking equipment.

The water pumped from the two well pumps is greater than the sum of all the taps' meter readings; this difference is categorized as unaccounted-for water. The distribution demands were

based on the well pump gallons per minute to include the unaccounted-for water. The water was distributed through the system using the taps' meter readings for percentages. This method distributes the unaccounted-for water evenly through the system.

In December 2016, Pump 2 averaged approximately 444 gallons per minute when it was running against a discharge head of approximately 195 psi. That performance exceeds the pump curve provided by RWC staff by approximately 54 gpm, which suggests one or more of the following issues: the pump curve is incorrect, the flow meter is incorrect, or the pressure gauge is incorrect. The model used the Pump 2 curve provided as it was the best available information.

Elevation information is critical in water modeling. Junction elevation information was taken from the previous model developed in 2009.

Despite the extensive data evaluation efforts and determining the most representative demand distribution, the information above does not provide adequate information to fully calibrate the model. Conventional model calibration involves measuring pressures and flows in the field and adjusting the model accordingly. Many issues can influence model performance, including:

- Groundwater table elevation
- Partially closed valves
 - RWC reports the main valves haven't been exercised in several years, possibly since 1999.
 - RWC reports the curb stops are exercised each year. Given the infrequency of main valve testing, this is a critical last-ditch program to minimize home flooding and should be continued.
- Air in pipelines
- Sediment in pipelines

The system has experienced occasional issues with water hammer, the last occurring for approximately one month during the summer of 2016. The water hammer events spike the pressure in various locations, however no specific cause has yet been identified. These events can cause pressure gauges to lose their calibration, so readings from existing pressure gauges installed before water hammer events may be suspect.

The NHDES adopted the 10 States Standards in Env-Dw 404.01(a), which requires the following pressures per section 8.2.1:

- Maintain a minimum pressure of 20 psi (140 kPa) at ground level at all points in the distribution system under all conditions of flow.
- The normal working pressure in the distribution system shall be at least 35 psi (240 kPa) and should be approximately 60 to 80 psi (410 - 550 kPa).

A reduction of operating system pressure will reduce the maximum available flow. A water demand during a fire is typically the highest instantaneous flow required from a distribution system. Horizons Engineering staff met with Omni Resorts Mount Washington staff to attempt to determine the design fire flow rates required for its structures, which are the largest in the

distribution system. After hours of searching through record documents and examining fire service entrances, only one complex' fire flow design criteria was found, which was for the Mount Washington Hotel's Spa/Conference center and had a maximum requirement of 880 gpm at 124 psi.

Fire flow rates vary depending on the local fire department. The Insurance Services Office (ISO) issues a Fire Suppression Rating Schedule that recommends fire flows for residential and commercial construction. The ISO fire flow range for residential buildings is typically from 500 to 1,500 gallons per minute (gpm). The Uniform Fire Code (UFC) requires a minimum of 1,000 gpm for residential buildings with areas up to 3,600 square feet. The National Fire Protection Association requires up to 8,000 gpm for up to 4 hours depending on the building fire flow area and construction type.

The modeling evaluated the system to supply a minimum of 1,000 gpm at the Mount Washington Hotel (MWH) at a minimum pressure of 20 psi because the MWH has a single, long, relatively small service pipeline that should represent the most difficult fire demand on the system.

EXISTING SYSTEM WATER MODELING RESULTS. The hydraulic modeling is based only on the system information entered into the system, which, while detailed, is not an exhaustive representation of system characteristics. It calculates a theoretical moment in time based on the stated assumptions and relatively evenly distributes the demands. Inaccuracies in the assumptions have varying degrees of impact on the system performance. Based on the information provided, the modeling results appear to be reasonable.

The following table lists average annual demand (AAD) and peak hour demand (PHD) results from the model. The modeling applied the fire flows to the peak hour demand.

Table 3 Existing System Hydraulic Modeling Results

Condition	Flow, gpm	Notes
AAD, NO fire flow	78	Low pressure at Dartmouth Ridge (node J-79) was 100 psi. Pressure at Crawford Ridge (node J-15) was 113 psi. Pressure at Rosebrook Townhomes (node J-22) was 121 psi. Pressure at the Mount Washington Hotel (node J-74) was 151 psi. High pressure 200' south of the water pump station (node J-3) was 190 psi.
PHD, NO fire flow	624	Low pressure at Dartmouth Ridge (node J-79) was 99 psi. Pressure at Crawford Ridge (node J-15) was 112 psi. Pressure at Rosebrook Townhomes (node J-22) was 121 psi. Pressure at the Mount Washington Hotel (node J-74) was 144 psi. High pressure 200' south of the water pump station (node J-3) was 190 psi.
PHD, 1,000 gpm fire flow at MWH	1,622	Low pressure at Dartmouth Ridge (node J-79) was 96 psi. Pressure at Crawford Ridge (node J-15) was 111 psi. Pressure at Rosebrook Townhomes (node J-22) was 120 psi. Pressure at the Mount Washington Hotel (node J-74) was 83 psi. High pressure 200' south of the water pump station (node J-3) was 189 psi.
PHD, 1,000 gpm fire flow at high point	1,622	Low pressure at Dartmouth Ridge (node J-79) was 81 psi. Pressure at Crawford Ridge (node J-15) was 111 psi. Pressure at Rosebrook Townhomes (node J-22) was 120 psi. Pressure at the Mount Washington Hotel (node J-74) was 141 psi. High pressure 200' south of the water pump station (node J-3) was 189 psi.

The hydraulic modeling of the existing system generally corroborated operations staff reports of system function. The goal of this project is to reduce the high pressures to no more than 120 psi if possible.

A schematic representation of the existing distribution system is provided in the following figure.

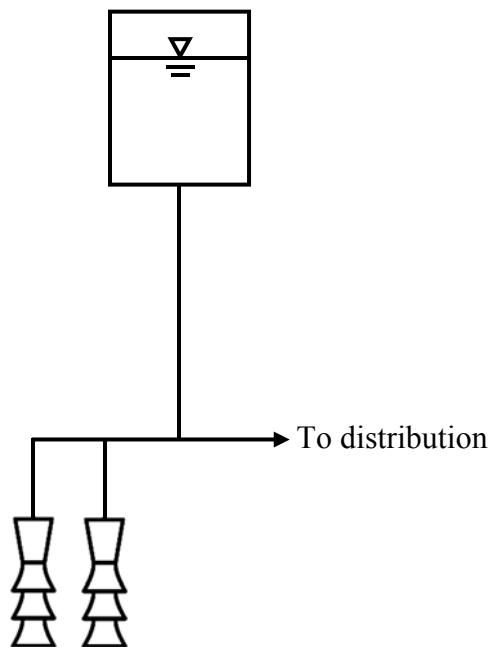

SYSTEM MODIFICATIONS

To reduce the maximum pressure in the lowest zone, multiple zones with booster stations are needed to supply water to the highest service areas. A 2016 preliminary report titled System Evaluation for Pressure Reduction by Horizons Engineering proposed a new storage tank at a lower elevation than the existing water storage tank as part of the distribution modifications. However, at the request of Rosebrook Water Company, the hydraulic model evaluation described herein relied on the existing storage tank and did not assume a new tank would be installed.

The basic operating criteria of the modified system are listed as follows:

- Zone 1 (lowest elevations) would serve elevations from approximately 1575 to 1700.
- Zone 2 (highest elevations) would serve elevations from approximately 1700 to 1845.
Preliminary designation assumptions were as follows to match the booster station locations:
 - Zone 2CR for Crawford Ridge
 - Zone 2MWP for Mount Washington Place
 - Zone 2RT for Rosebrook Townhomes
- Minimum pressure during fire flow = 20 psi
- Minimum pressure during normal operation = 35 psi, try to maintain 45 psi = 104 feet
 - Zone 1: maintain a minimum hydraulic grade line of 1804 feet at the highest elevations
 - Zone 2: maintain a minimum hydraulic grade line of 1949 feet at the highest elevations

Two primary alternative configurations were considered to reduce the service pressures, which are summarized as follows and discussed further in the table below. Alternative 1 was the concept discussed in the 2016 System Evaluation for Pressure Reduction report. Both alternatives use the existing ~650,000-gallon water storage tank.

ALTERNATIVE 1 – EXISTING TANK, BOOSTER PUMP STATIONS/PRVs: Modify the existing well pumps to serve the lowest pressure zone (Zone 1) and install three booster stations to serve higher elevations (Zones 2CR, 2MWP, and 2RT). The well pump modifications would include a minimum of adding a variable frequency drive (VFD) to Pump 2 and replacing the Pump 2 motor with an inverter-duty motor to be compatible with a VFD. The wells would pump into Zone 1 based on storage tank elevation setpoints, and the water storage tank would be filled by the Rosebrook Townhomes booster station. Based on the modeling results, it might be possible to continue to use the two existing well pumps, however complete replacement might be necessary to adequately reduce their flow and pressure capacity. A schematic representation of this configuration is provided in the following figure.

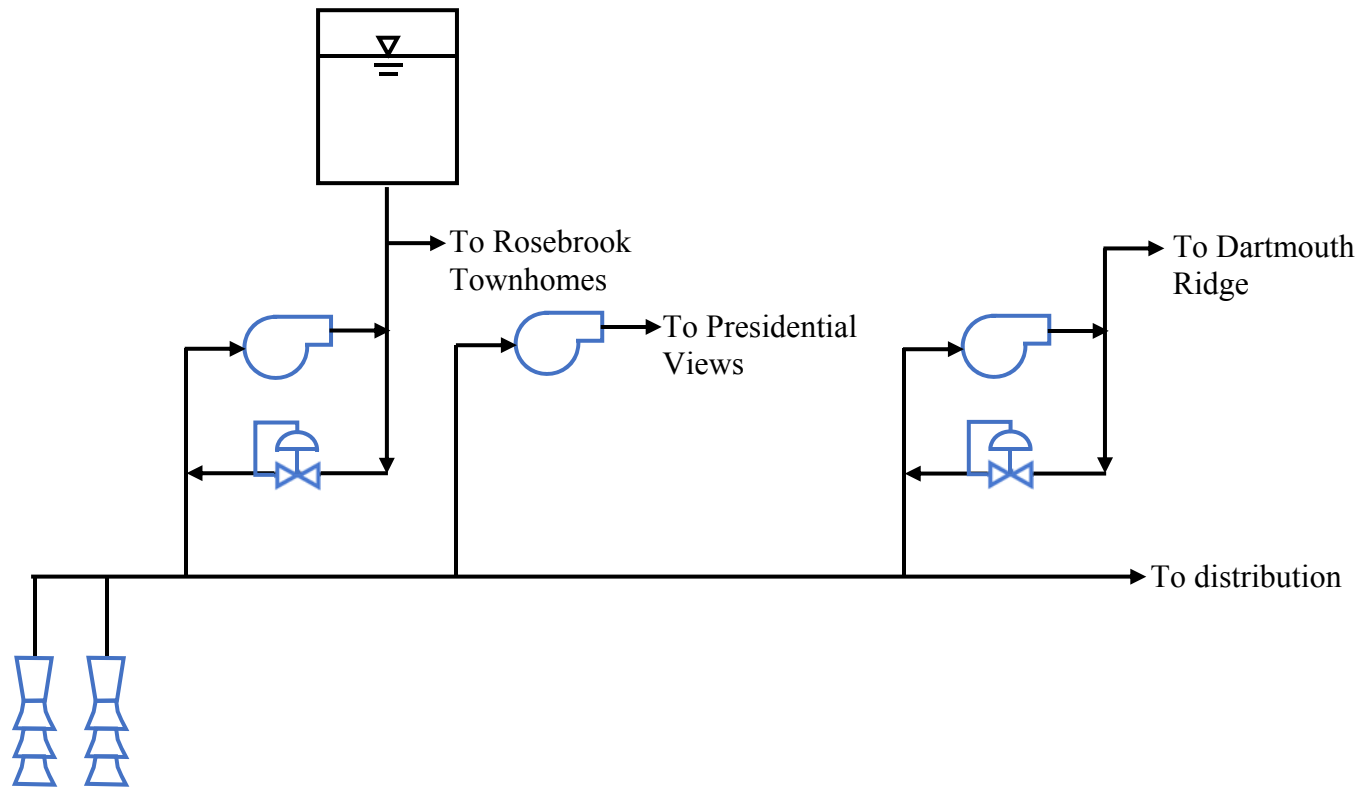

Applying pump affinity laws to well pumps 1 and 2 and assuming the maximum turndown using a variable frequency drive would be 60 percent suggests the pumps’ minimum performance would be approximately as listed in the following table.

Table 4 Existing Well Pump Performance Characteristics at 60 Percent Speed

Pump	Shutoff Head, ft	Design Flow, gpm	Head, ft	Max Flow, gpm	Head, ft
Well Pump 1 (50 hp)	330	180	285	285	201
Well Pump 2 (60 hp)	416	210	297	300	174

The performance listed above is theoretical and, if Alternative 1 will be pursued further, we recommend testing the existing Pump 1 by running its VFD at its minimum speed to confirm the limits of its capabilities if possible. Well pump 2 would require a variable speed drive and might require replacement of its pump with an inverter duty motor.

ALTERNATIVE 2 – EXISTING TANK, NEW SUPPLY PIPELINE/PRVs: Use the existing well pumps to pump directly to the existing water storage tank via a new dedicated pipeline. The distribution system would then be fed by gravity off the existing storage tank and would require two booster stations to serve higher elevations. The distribution system would have four separate pressure zones: Zone 1 (lowest elevation), Zone 2CR (fed by a new booster station), Zone 2MWP (fed by a new booster station), and Zone 2RT (fed by gravity from the existing storage tank). The dedicated pipeline between the wells and the storage tank would have no supply taps, would generally follow existing water pipeline alignments, and would require high pressure (~190 psi) at the existing well pump house. A schematic representation of this configuration is provided in the following figure.

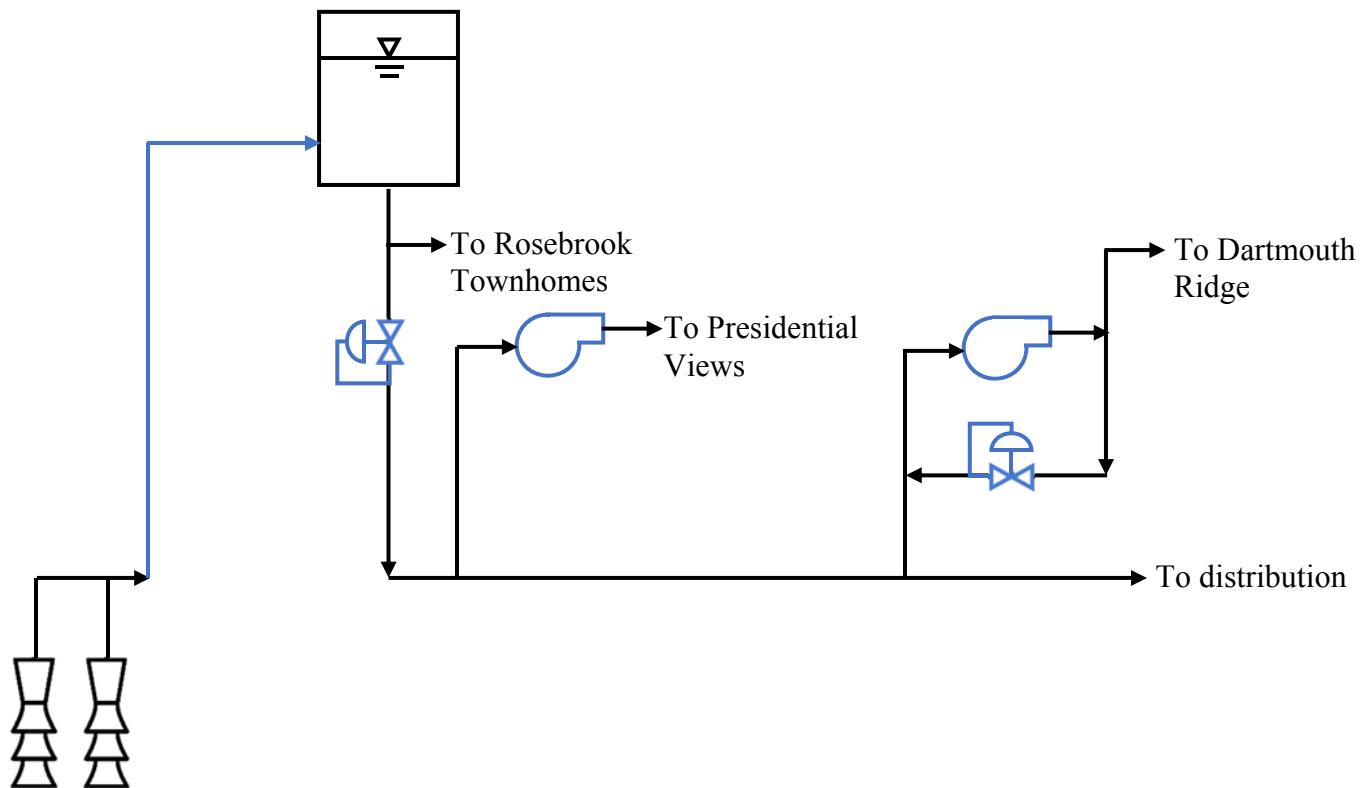

Table 5 System Modifications Alternatives Comparison

Description	Pros	Cons
ALTERNATIVE 1 – EXISTING TANK, BOOSTER PUMP STATIONS/PRVs		
Modify well Pump 2 and install 3 booster stations	<ul style="list-style-type: none"> • No major pipelines needed 	<ul style="list-style-type: none"> • Pump 2 VFD required; replacement of both pumps may be required depending on actual maximum turndown • Higher operation and maintenance costs due to one additional booster pump station compared to Alternative 2 • The Rosebrook Townhomes booster station siting is expected to be particularly exposed to view and potential vehicle damage.
ALTERNATIVE 2 – EXISTING TANK, NEW SUPPLY PIPELINE/PRVs		
Install ~4,300 feet of 8” or 6” pipeline from wells to the existing storage tank and install 2 booster stations	<ul style="list-style-type: none"> • Only 2 booster pump stations needed (for Presidential Views and Mt. Wash. Pl.); Rosebrook Townhomes can be fed by gravity • Existing 2 well pumps can be used • Pipeline can be smaller than the current 16” tank connection • New pipeline connection opposite the existing connection would turn over water in the existing storage tank more often, which would improve tank water quality • Lower operation and maintenance costs due to one less booster pump station compared to Alternative 1 	<ul style="list-style-type: none"> • Pipeline would need to cross the Ammonoosuc River • High pressure (~190 psi) would be required in the existing pump house

Regarding the booster stations and pressure reducing valves, the following criteria were assumed for each location:

Crawford Ridge Booster Station

- Floor elevation = 1710
- Serves buildings up to elevation = 1845
- Normal duty pump capacity = 0 to 40 gpm
- Features:
 - Variable frequency drive for each pump
 - Emergency power generator

Mount Washington Place Booster Station

- Floor elevation = 1680
- Serves buildings up to elevation = 1825
- Normal duty pump capacity = 0 to 80 gpm
- Features:
 - Variable frequency drive for each pump
 - Emergency power generator

Mount Adams Lane Pressure Reducing Valve

- Valve elevation = 1700
- Valve size = 6 inch
- Valve downstream setpoint = approximately 30 psi (1804 - 1700 = 104 feet = 45 psi is too high in the model as the Zone 2MWP booster station pumps in a loop during high flow rates)

Rosebrook Townhomes Booster Station

- Floor elevation = 1680
- Serves buildings up to elevation = 1810
- Normal duty pump capacity = 0 to 80 gpm
- Features:
 - Variable frequency drive for each pump
 - Emergency power generator

Rosebrook Townhomes Pressure Reducing Valve

- Valve elevation = 1725
- Valve size = 8 inch
- Valve downstream setpoint = approximately 86 psi (1804 - 1725 = 79 feet = 34 psi)

SYSTEM MODIFICATIONS WATER MODELING RESULTS. The hydraulic modeling revealed a critical problem with the system during fire flow conditions. The end of the Mount Washington Hotel water supply connection consists of approximately 4,300 feet of 8-inch piping, which connects to the main distribution system’s 16-inch trunk pipeline. When a 1,000 gpm fire flow is supplied to the hotel during peak hour conditions, the total flow is over 1,600 gallons per minute, which has a velocity of over 9 feet per second in an 8-inch pipeline. This high velocity yields significant pressure loss – so much that the initial runs for both alternatives resulted in negative pressures at the hotel.

After considering several options, the most efficient solution would be to install a short interconnection between the 16-inch main pipeline in Base Station Road with the 8-inch hotel supply pipeline. This interconnection allows the water to flow through both the 8-inch and 16-inch pipelines to reach the hotel. The interconnection would likely be located just north of the Stables building. If additional flow or pressure becomes necessary at the hotel or other nearby buildings, the 8-inch supply pipeline could be upsized from this interconnection point towards the hotel. The short interconnection was necessary to make either alternative viable.

Modeling Alternatives 1 and 2 worked as a steady state analysis, however due to the complicated controls required by the pump systems operating in series up to the storage tank, it was necessary to model Alternative 1 as an extended period simulation to identify feedback problems with pump and pressure reducing valve setpoints. After many iterations using different infrastructure locations and control scenarios, a suitable and relatively simple configuration was identified.

Based on the evaluation findings, the following tables list the modeling results for both alternatives including the 16-inch pipeline interconnection. The modeling applied the fire flows to the peak hour demand. An example graphic output from the software is shown below.

Table 6 Alternative 1 Modified Well Pumps Hydraulic Modeling Results

Condition	Flow, gpm	Notes
AAD, NO fire flow	78	Low pressure at Dartmouth Ridge (node J-79) was 45 psi*. Pressure at Crawford Ridge (node J-15) was 56 psi*. Pressure at Rosebrook Townhomes (node J-22) was 121 psi. Pressure at the Mount Washington Hotel (node J-74) was 66 psi. High pressure 200’ south of the water pump station (node J-3) was 105 psi.
PHD, NO fire flow	624	Low pressure at Dartmouth Ridge (node J-79) was 45 psi*. Pressure at Crawford Ridge (node J-15) was 56 psi*. Pressure at Rosebrook Townhomes (node J-22) was 121 psi. Pressure at the Mount Washington Hotel (node J-74) was 63 psi. High pressure 200’ south of the water pump station (node J-3) was 105 psi.
PHD, 1,000 gpm fire flow at MWH	1,622	Low pressure at Dartmouth Ridge (node J-79) was 45 psi*. Pressure at Crawford Ridge (node J-15) was 56 psi*. Pressure at Rosebrook Townhomes (node J-22) was 120 psi. Pressure at the Mount Washington Hotel (node J-74) was 34 psi. High pressure 200’ south of the water pump station (node J-3) was 104 psi.

Note: 1. Model run as an extended period simulation.
 2. The system pressures in Dartmouth Ridge and Crawford Ridge would be controlled by the selected setpoints for their respective new booster stations. The exact setpoints would be determined during final design.

3. The fire flow condition was assumed to last for three hours and assumed both well pumps 1 and 2 turned on. The majority of the fire flow water came directly from the water storage tank.

Table 7 Alternative 2 New Supply Pipeline Hydraulic Modeling Results

Condition	Flow, gpm	Notes
AAD, NO fire flow	78	Low pressure at Dartmouth Ridge (node J-79) was 50 psi. Pressure at Crawford Ridge (node J-15) was 61 psi. Pressure at Rosebrook Townhomes (node J-22) was 121 psi. Pressure at the Mount Washington Hotel (node J-74) was 66 psi. High pressure 200' south of the water pump station (node J-3) was 105 psi.
PHD, NO fire flow	624	Low pressure at Dartmouth Ridge (node J-79) was 50 psi. Pressure at Crawford Ridge (node J-15) was 61 psi. Pressure at Rosebrook Townhomes (node J-22) was 121 psi. Pressure at the Mount Washington Hotel (node J-74) was 61 psi. High pressure 200' south of the water pump station (node J-3) was 104 psi.
PHD, 1,000 gpm fire flow at MWH	1,622	Low pressure at Dartmouth Ridge (node J-79) was 50 psi. Pressure at Crawford Ridge (node J-15) was 61 psi. Pressure at Rosebrook Townhomes (node J-22) was 118 psi. Pressure at the Mount Washington Hotel (node J-74) was 24 psi. High pressure 200' south of the water pump station (node J-3) was 94 psi.

Note: 1. Model run as a steady state.
 2. The system pressures in Dartmouth Ridge and Crawford Ridge would be controlled by the selected setpoints for their respective new booster stations. The exact setpoints would be determined during final design.

Scenario: Existing PHD + MWH FF EPS

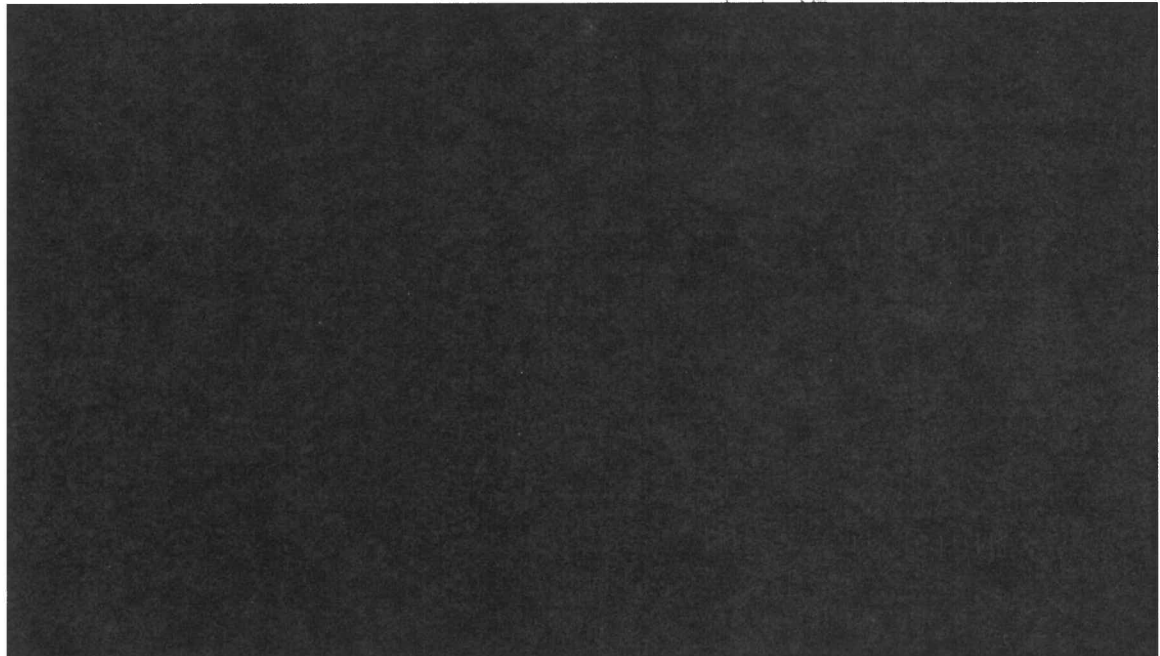

Both alternatives are viable. Alternative 1 appears to provide slightly higher pressure to the hotel during a fire flow and it keeps operating pressure at the well pump house relatively low (refer to results for node J-3). As expected, the pump controls were critical to the system's operation. The VFDs for the Crawford Ridge and Mount Washington Place booster stations were set to maintain a target discharge pressure, which would be operator-adjustable. The Rosebrook Townhomes booster station would serve to fill the storage tank, which would maintain the distribution pressure for the upper Rosebrook Townhomes and for the Mountain View homes. The well pumps would operate based on the storage tank level, as they do now. The Rosebrook booster station pumps would turn on and off in conjunction with the well pumps.

The upper Rosebrook zone (Zone 2RT) will still have pressures approaching 130 psi, which is unavoidable without an additional PRV close to the tank or a new lower water storage tank (which was the intent of the 2016 preliminary report) due to the ~310-foot maximum elevation difference between the storage tank and the homes (= 2010 – 1700).

Structures in Zones 2CR and 2MWP will have a maximum available flow based on their respective booster stations. Each booster station can provide a range of flows, and a higher maximum flow will increase the minimum flow capacity. At low flows such as in the middle of the night, the booster pumps are expected to cycle on and off frequently depending on the minimum flow capacity of the system. The maximum flow is currently expected to be approximately 300 gallons per minute.

Several of the modeling assumptions were conservative, including assuming peak hour demand rather than maximum day demand for the fire flow condition and assuming a peaking factor of eight rather than six. However, there are also unresolved factors that carry some risk and could be studied further, including the assumed water storage tank elevations, the identification of required fire flow rates for each sprinkled structure, and some operational discrepancies such as differences between pump performance curves and reported pumped water quantities.